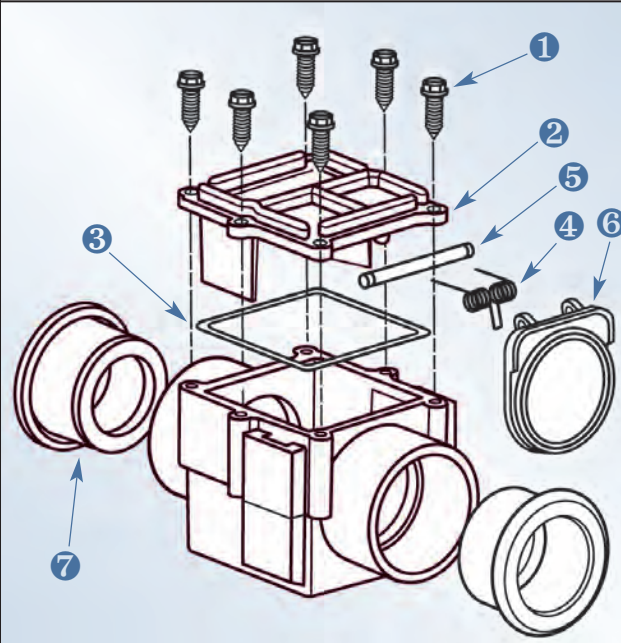

CHECK VALVE REPLACEMENT COMPONENTS

DESCRIPTION	ID	PART NUMBER	SIZE AND DETAIL DESCRIPTION	PACKAGE QUANTITY	LIST PRICE
	1	0403-006-6	#14 x 1" Phillips Pan Head Stainless Metal Screw	6	8.26
	2	0191401020	Lid, 2" Swing-Spring Check Valve	1	9.59
	3	0301-154	O-Ring, 2" Swing-Spring Check Valve	1	2.98
	4	0405-001	Spring, 2" Swing-Spring Check Valve	1	3.92
	4	0405-001-H	Hastelloy Spring	1	14.67
	5	0401-005P	Shaft, 2" Swing-Spring Check Valve	1	4.32
	6	0081201020	Gate Assembly, 2" Swing-Spring Check Valve	1	15.38
	7	0060104028	Adapter, 2" Spigot x 1½" Slip White	1	2.45
	RK	0801-20H-RK	Replacement Kit, Check Valve Contains ID# 2, 3, 4(H), 5 & 6	1	33.25