

# "MAGNA" CHECK™

BY MAGIC PLASTICS

## The First Water Conditioning Check Valve

**MAGIC**  
P L A S T I C S

The "Magna" Check™ is a unique, spring-loaded, positive-seal back flow prevention check valve equipped with high-quality water-conditioning magnets. The magnetic power provides a natural and safe solution to brighter, clearer, healthier water in pools and spas.

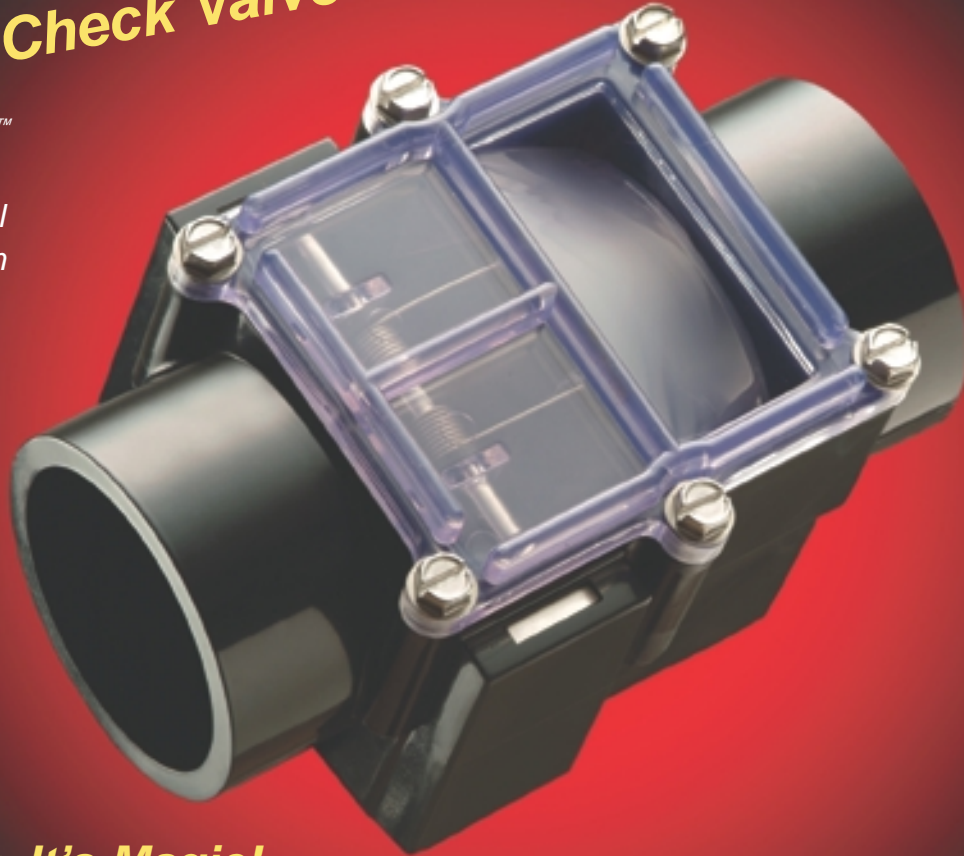

### Check it Out. It's Magic!

#### Check Valve Benefits:

- 100% positive seal. No minimum head pressure required.
- UV stabilized sight glass lid.
- Stainless steel spring\*.
- Glass-Filled PVC gate.
- High temperature CPVC body.
- One valve, 3 sizes: 1½" Slip, 2" Slip and 2½" Spigot.
- Silicone seal never requires lubrication.
- Specifically designed for the pool and spa industry.
- Body and lid designed for maximum flow/minimum cavitation.

\*For more demanding applications, a Hastelloy® corrosion-resistant spring is also available.

#### Water-Conditioning System:

- Reduces water hardness.
- Improves water clarity.
- Helps prevent mineral staining.
- Decreases scale buildup.
- Assists in stabilization of chemical balance.
- Moderates your chemical usage.
- Minimizes pool and spa maintenance.
- Environmentally friendly.
- A natural, non-toxic, answer to cleaner water.

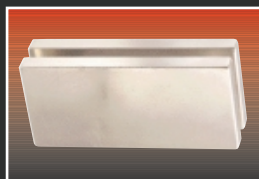

Proudly manufactured and assembled in the U.S.A.

Magic Plastics, Incorporated • 25215 Avenue Stanford • Valencia, California 91355 USA  
(661) 257-4485 • Toll-Free (800) 369-0303 • Fax: (661) 257-4425 • [www.magicplastics.com](http://www.magicplastics.com) • email: [sales@magicplastics.com](mailto:sales@magicplastics.com)

MEMBER  
  
NATIONAL  
SPA & POOL  
INSTITUTE

# "MAGNA" CHECK™

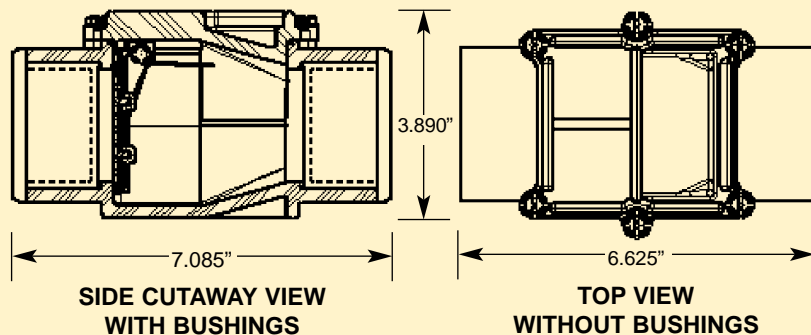

PHOTO COURTESY OF VENTURA POOL & SPA, INC.

| Part Number | Description                    | Material   | Length  | Height | Case Qty. |
|-------------|--------------------------------|------------|---------|--------|-----------|
| 0801-20     | 2" Swing-Spring Check          | PVC White  | 6.625"* | 3.890" | 12        |
| 0802-20     | 2" "Magna" Check™ Swing-Spring | CPVC Black | 6.625"* | 3.890" | 12        |

\*Length of both valves with 1 1/2" bushings installed is 7.085". Reducer bushings included with "Magna" Check™ only.

THE "Magna" Check™. Exclusively from Magic Plastics, Inc. A spring-loaded backflow prevention check valve equipped with super-strength water conditioning magnets. The "Magna" Check™ main body is manufactured from a high temperature CPVC and the clear UV stabilized lid allows you to identify debris and also can be easily removed for service. The "Magna" Check™ offers maximum flow and minimal cavitation with its unique flow-through body and lid design. The liquid injection molded silicone seal never requires lubrication and provides a 100% shut-off, allowing you to install the "Magna" Check™ in practically any location. Two Neodymium-Iron-Boron magnets with Gauss ratings of 12,500 aid in the reduction of water hardness, decrease scale buildup, hinder corrosion and improve overall water clarity. Additionally, reducer bushings are included with every "Magna" Check™, providing you with three sizes in one valve (1 1/2" Slip, 2" Slip and 2 1/2" Spigot).



Should your application not require the industrial strength or water conditioning benefits of the "Magna" Check™, an economy version is also available. Please contact the factory for details.



**Magic Plastics, Incorporated**  
 25215 Avenue Stanford • Valencia, California 91355 USA  
 (661) 257-4485 • Toll-Free (800) 369-0303 • Fax: (661) 257-4425  
[www.magicplastics.com](http://www.magicplastics.com) • email: [sales@magicplastics.com](mailto:sales@magicplastics.com)

The magnets utilized in this product are extremely powerful. Please do not attempt to remove them from their compartments. Magic Plastics, Incorporated assumes no responsibility for damage or injuries due to the removal or misuse of magnets.



P L A S T I C S